



Predictive Machining: Learning to Stop Failures in Their Tracks

How secure, real-time delivery of machine data maximizes uptime and increases maintenance efficiencies



Understanding the Value of Predictive Maintenance

On the shop floor, industry veterans know red lights mean trouble. LED stack lights and displays are tried and true methods to alert workers about machine failures or maintenance issues. These sensor-based signals have evolved into more sophisticated predictive systems that can detect problems well before they occur.

It's called the Internet of Things (IoT), or Industry 4.0, and it's driving a shift toward proactive maintenance. More manufacturers are realizing the value of IoT-enabled maintenance, with 40% of organizations planning to adopt predictive technologies by 2022.¹

IoT delivers insights about machine performance that help manufacturers maximize uptime, so they can meet customer demands and production goals. Other key benefits related to predictive maintenance include:

- Visibility into potential failures long before they occur
- The ability to optimize maintenance schedules
- Fewer part defects due to poor machine performance or failures
- The ability to plan ahead for scheduled shutdowns

Predictive maintenance is a necessity in today's fast-paced manufacturing environment. But IoT adoption is often hindered by security and data analysis challenges. Manufacturers may be concerned about sending sensitive data to the cloud or lack the ability to analyze the data that's streaming from their connected machines.

In this white paper, we'll take a closer look at the benefits of a secure, IoT-enabled predictive maintenance platform.

Working Toward a Failure-Free Future

Predictive maintenance helps organizations remain agile by providing the information they need to make fast decisions related to machine performance. Speed is critical in an increasingly competitive market. Pressure from global competitors and tighter lead times mean manufacturers can't afford downtime.

Machine failures can lead to costly shutdowns and part defects. Real-time visibility into performance allows manufacturers to address maintenance issues before they lead to more serious problems. Typical predictive maintenance configurations include machines with smart sensors that deliver data over a network to external programs that store the information or provide additional analytical insights.

The information, particularly when it's paired with a machine learning or artificial intelligence platform, can help manufacturers identify anomalies in performance or trends that indicate potential maintenance issues. The ability to detect problems early on helps manufacturers plan for the future. They can optimize their maintenance schedules so they're only working on machines when necessary.

Service teams are more efficient and cost effective. When manufacturers detect problems, they can build safety stock to ensure they can meet their customer requirements during a planned shutdown. They also know which parts or tools they need on hand prior to servicing the equipment, which reduces the likelihood of extended downtime due to maintenance inventory shortages.

Health Check: Critical Systems to Monitor

The leading causes of unplanned downtime are often related to problems with the spindle, coolant, hydraulics or tool changer. A closer look at each function shows why they're critical systems to monitor:

Tool changer: This is perhaps the most important component to maintain for sustained production. Technicians need insight into the tool changer system's overall mechanical health as well as its alignment over time to the spindle.

Spindle health: Predictive maintenance systems can evaluate the health of the spindle using data gathered by an integrated high frequency vibration sensor. This system is capable of tracking and analyzing the vibration looking for key indicators to understand the true health of the spindle.

Coolant: The coolant system is critical for evacuating chips from both the cut as well as from the machine, enabling sustained machine operation, long tool life and fine surface finishes. Predictive systems can monitor and analyze each main branch of this system and alert technicians or managers about developing trends that indicate a need to service the equipment.

Hydraulics: The hydraulic system is another important function that can cause machine failures if it's not operating properly. Predictive tools can monitor system pressure and temperature, building a body of data used for trend analysis-based predictions of developing needs.

Monitoring essential machine functions requires a secure IoT system that can perform trend analyses and deliver immediate alerts about items that could result in future unplanned downtime.

Prioritize Security to Protect Valuable Data

There's no question that some IoT solutions pose security risks if manufacturers are not cautious when they're evaluating predictive maintenance tools.

Traditional IoT systems collect data from multiple machines across different shops, and compare machine performance to detect anomalies. The large volume of data typically requires a cloud architecture to store and process the information. Part information and numerical control program data are extremely valuable to manufacturers. Exposing that data to unsecured networks puts it at risk.

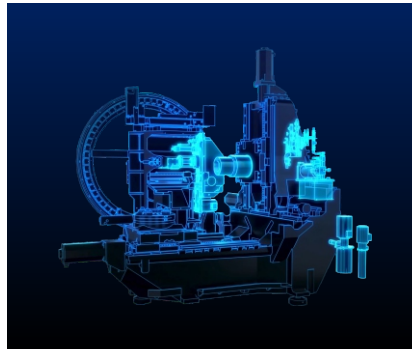

The lack of data control and ownership in traditional IoT systems is a major concern for manufacturers. In fact, a Bain & Company study showed that enterprise customers would buy more IoT devices and pay 22% more on average for solutions that addressed their security concerns.²

Makino is addressing many of these security issues with a predictive maintenance platform called MHmax™, which doesn't require users to store their data in the cloud, even when they connect their machines to the internet. Often referred to as "fog computing," this configuration enables "the distribution of computing and control, storage, and networking functions closer to end-user devices (or 'things')." ³ The fog ensures computing, control and communication occur at or near the device, which reduces exposure to outside attacks.⁴

Predictive Maintenance in Action

The value of predictive insights is being realized across a wide range of industries. But the capabilities and security in the various solutions on the market can vary considerably. Manufacturers must be mindful of what key performance indicators are essential for their operations as well as the level of visibility and security they need. Newer predictive tools, such as MHmax™, can deliver meaningful data without the vulnerabilities inherent in many other IoT-enabled platforms.

This includes the use of a specialized processor that continually analyzes thousands of data points to monitor the status of the machine and predict issues using a proprietary algorithm. For instance, MHmax™ provides access to a color-coded display that shows the health of critical systems in real time with three tiers of connectivity to choose from, including:

Level 1: Users who select this option don't have to worry about their machines transmitting any data over a network. Connectivity lives on the machine itself. A multi-color display screen on the machine's Pro6 control shows the status of all monitored systems on the machine in a green/yellow/red gradient, which indicates whether various functions are operating within acceptable limits. NOTE: Level 1 connectivity applies to Pro6 control equipped Makino machines only.

Level 2: At this level, connectivity is expanded to the "fog" or a localized cloud. Data moves from one or more machines to an in-plant network system. Employees can log in to an MHmax™ summary page and instantly have visibility to the health status of all connected machines. Custom views of connected machines can be grouped and named using any convention that is most appropriate, and notifications can be sent directly to staff via text or email. The information still does not leave the plant. It remains within the facility's intranet. The data also is still viewable on the machine itself. NOTE: Level 2 connectivity applies to both Pro5 and Pro6 control equipped Makino machines.

Level 3: The highest level of connectivity enables machines to send coded alarm messages to Makino that trigger automated support requests directly to Makino's technical support team. The Makino support team will then contact user to discuss a recommended course of action in real time. Connectivity occurs through a push notification through a designated port on the user's server for outbound-only traffic. No proprietary data is being transmitted. Users also can receive text and email alerts about maintenance issues. NOTE: Level 3 connectivity applies to both Pro5 and Pro6 control equipped Makino machines.

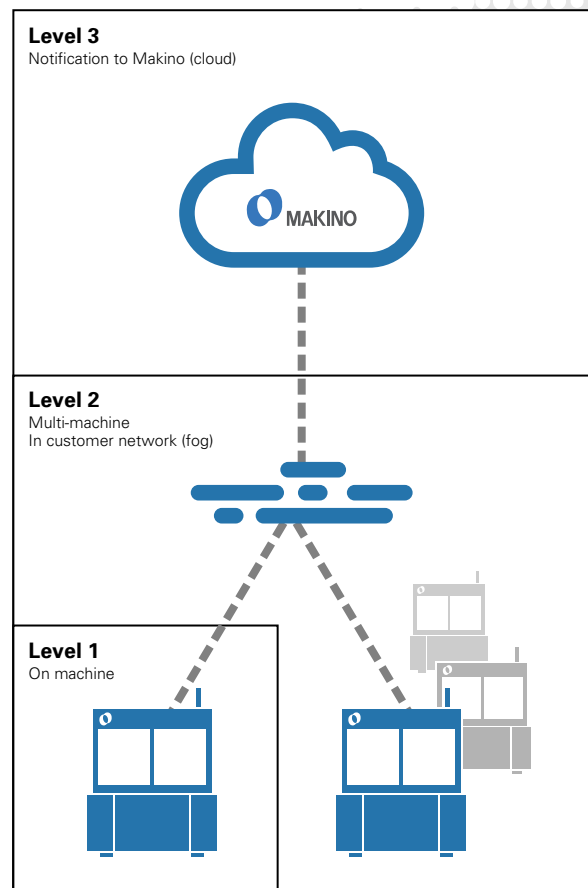

Platform Advantages and Selection Tips

The option that a user selects will depend on the shop's comfort level and requirements. For example, a manufacturer that sells parts to a customer with high security requirements, such as the Department of Defense, may opt for Level 1 or Level 2 connectivity because they know the information never leaves the plant.

At Level 2, the same features that are available on the control in Level 1 are now viewable on all MHmax™- enabled machines in their facility via a customizable internal only intranet site. This software, when given access to a mail client, is capable of sending reports and alerts to users. They also have access to an analytics drop-down tab that shows trending graphs and charts related to the performance history.

If anything is operating outside its normal boundaries, team members will receive alerts. For example, if someone receives an alert about the coolant system, the user would log on to the platform and see that the coolant icon was shaded red. They also can view historical data to understand the trends or event history associated with this system.

A shop may want to view how a subsystem performs over time to see any trends that may indicate performance issues. MHmax™ is capable of generating daily reports that the maintenance staff can use to view the current state of their machine condition or any past-due service items they must address, including a comparison of the recommended maintenance items and the actual actions taken. In addition, the maintenance team can access links within the platform to purchase parts, communicate with training staff or technical support.

Manufacturers that want to maximize the performance of this IoT solution to further minimize maintenance response times to issues and potential downtime can opt for Level 3 connectivity, where users gain all the benefits of Level 2 but also can send alerts directly to Makino's service team. While an internet connection is required at Level 3, the sensors

send information through a designated port on the user's server designed only for outbound traffic. The sensor sends a message that includes nothing more than the name, rank and serial number of the machine and the alarm code.

If anything is operating outside its normal boundaries, team members will receive alerts. For example, if someone receives an alert about the coolant system, the user would log on to the platform and see that the coolant icon was shaded red. They also can view historical data to understand the trends or event history associated with this system.

A shop may want to view how a subsystem performs over time to see any trends that may indicate performance issues. MHmax™ is capable of generating daily reports that the maintenance staff can use to view the current state of their machine condition or any past-due service items they must address, including a comparison of the recommended maintenance items and the actual actions taken. In addition, the maintenance team can access links within the platform to purchase parts, communicate with training staff or technical support.

Manufacturers that want to maximize the performance of this IoT solution to further minimize maintenance response times to issues and potential downtime can opt for Level 3 connectivity, where users gain all the benefits of Level 2 but also can send alerts directly to Makino's service team. While an internet connection is required at Level 3, the sensors send information through a designated port on the user's server designed only for outbound traffic. The sensor sends a message that includes nothing more than the name, rank and serial number of the machine and the alarm code.



Time to Take Control

Predictive maintenance puts manufacturers in control of their machine performance. Outdated reactive approaches are not sustainable in today's on-demand market. Downtime can lead to missed deliveries and lost revenue. According to one industry report, unplanned downtime costs manufacturers about \$50 billion each year.⁵

Overreliance on preventive maintenance schedules often lead to inefficient and unnecessary servicing of equipment. Predictive maintenance provides manufacturers with the tools they need to adopt a more proactive, cost-effective service strategy.

Predictive maintenance doesn't have to come with the security risks that are present in many cloud based IoT systems. MHmax™ is now available as an option on numerous 1-series Makino horizontal machining centers equipped with either the Pro5 or Pro6 control. For more information on how to take advantage of predictive insights with the highest levels of security available, contact Makino.



-
1. Gartner Inc., cited in the Wall Street Journal, "Budweiser Maker Uses Machine Learning to Keep Beverages Flowing," Jan. 23, 2019.
 2. <https://www.bain.com/insights/unlocking-opportunities-in-the-internet-of-things>.
 3. <https://www.openfogconsortium.org/top-5-ways-fog-computing-can-makeiot-more-secure>.
 4. *ibid.*
 5. Wall Street Journal custom article, "How Manufacturers Achieve Top Quartile Performance".